

DOMINA HP - DOMINA HP COVER

| | | | |
|-----------|--|------------------|----|
| CE | GSG INTERNATIONAL S.p.A. Via Tubertini, 1 40054 Budrio Bologna - Italy | | 10 |
| | 0757 | BPR-229-10-011 | |
| | EN1935:2002 | | |
| | | 4 7 7 0 1 4 1 14 | |

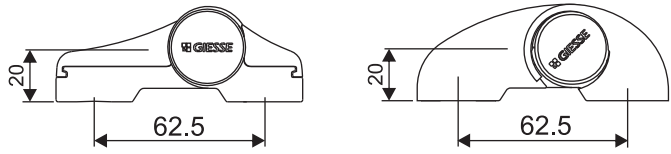

| | | | |
|-----------|--|------------------|----|
| CE | GSG INTERNATIONAL S.p.A. Via Tubertini, 1 40054 Budrio Bologna - Italy | | 10 |
| | 0757 | BPR-229-10-011 | |
| | EN1935:2002 | | |
| | | 4 7 5 0 1 4 1 12 | |

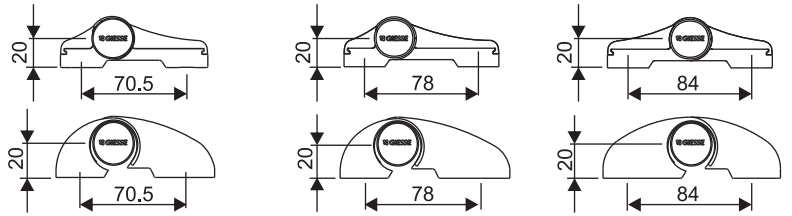

| | | | |
|-----------|--|------------------|----|
| CE | GSG INTERNATIONAL S.p.A. Via Tubertini, 1 40054 Budrio Bologna - Italy | | 10 |
| | 0757 | BPR-229-10-011 | |
| | EN1935:2002 | | |
| | | 4 7 5 0 1 4 1 12 | |



| | | | |
|-----------|--|------------------|----|
| CE | GSG INTERNATIONAL S.p.A. Via Tubertini, 1 40054 Budrio Bologna - Italy | | 10 |
| | 0757 | BPR-229-10-011 | |
| | EN1935:2002 | | |
| | | 4 7 7 0 1 4 1 14 | |

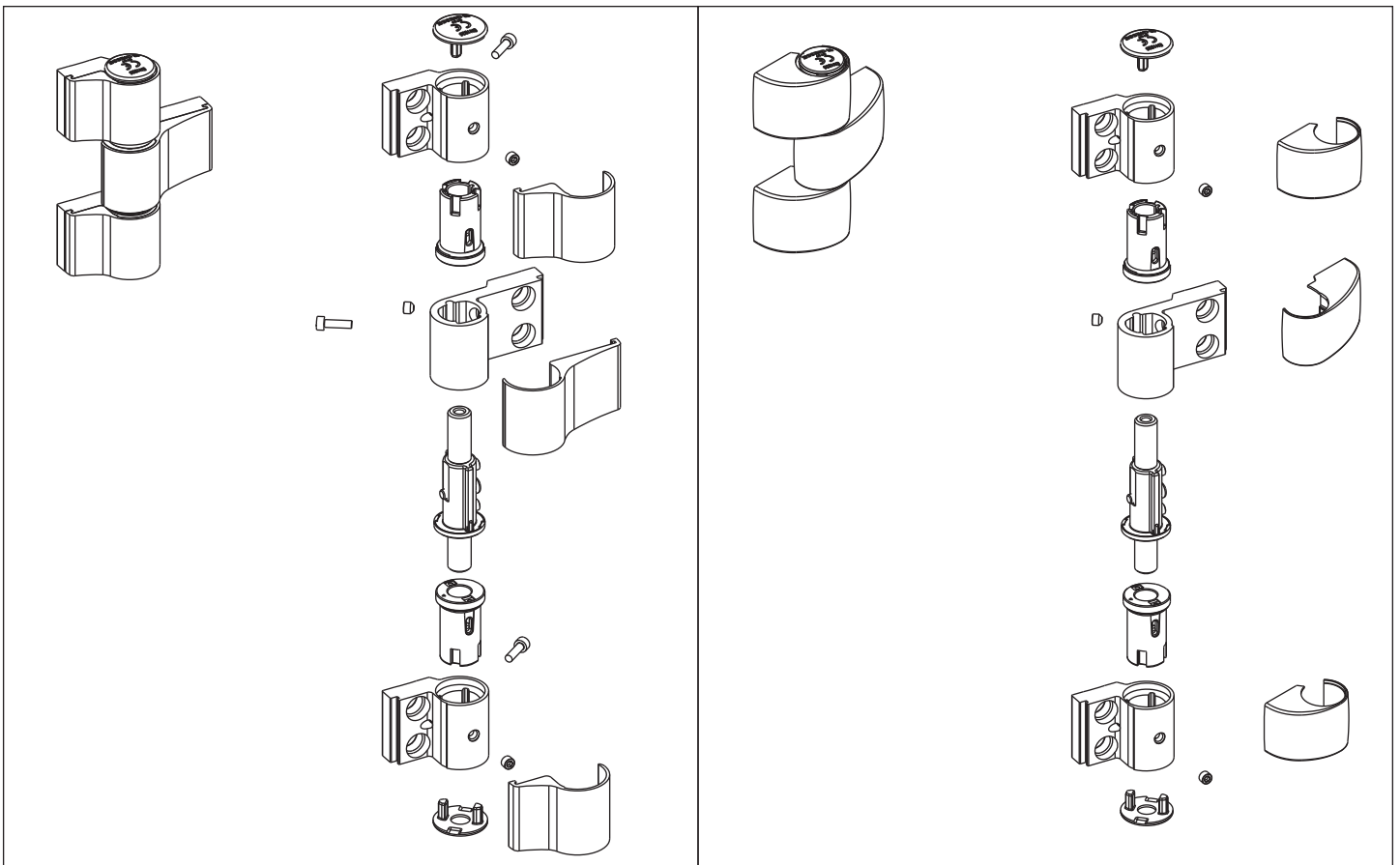
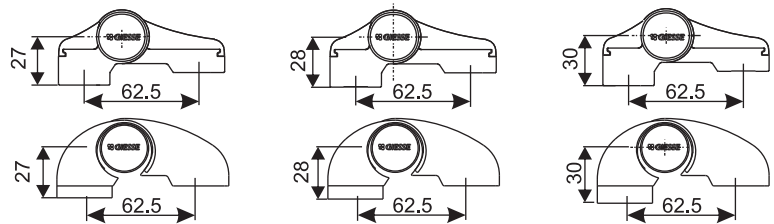

AVVERTENZE GENERALI - GENERAL WARNINGS - NOTICES GÉNÉRALES - ADVERTENCIAS GENERALES - ALLGEMEINE ANWEISUNGEN

Le classificazioni si riferiscono alle prestazioni della singola cerniera testate secondo EN1935:2002. Per l'effettiva portata della cerniera in funzione del numero e del tipo di cerniera, del tipo di fissaggio, delle caratteristiche del profilo e delle dimensioni e peso della porta, fare riferimento alla sezione COEFFICIENTE DI RIDUZIONE PESO ANTA (CRP)

In caso di applicazione su porte con alta frequenza di apertura, è fortemente raccomandata la lubrificazione del perno della cerniera con grasso, da ripetere almeno due volte all'anno (vedi figura 1).

L'efficacia e la sicurezza del prodotto sono garantite dall'osservanza di queste istruzioni, pertanto si raccomanda di leggerle attentamente e comprenderle bene prima di utilizzare il prodotto.

Il prodotto è stato progettato per essere installato con facilità. Occorre seguire attentamente le istruzioni di montaggio, smontaggio e manutenzione qui riportate. Si consiglia di far installare il prodotto da personale specializzato.

Utilizzare esclusivamente gli accessori consigliati nel presente documento.

Il prodotto è costruito secondo le vigenti normative europee.

È essenziale che vengano rispettati i limiti di impiego previsti dal Produttore.

Responsabilità e garanzia del Produttore decadono se non vengono rispettati i limiti di impiego e/o se per gli accessori previsti, non vengono seguite le istruzioni di montaggio riportate nel presente documento.

Classifications refer to the performance of a single hinge tested as provided by EN1935:2002. For the effective load capacity of the hinge as a function of the number and type of hinges used, type of mounting, characteristics of the profile and size and weight of the door, see the DOOR WEIGHT REDUCTION COEFFICIENT (CRP).

If fitted to doors subject to heavy service, we recommend lubricating the hinge pin with grease at least twice a year (see figure 1).

The effectiveness and safety of the product depend on these instructions being observed; read them carefully before using the product.

The product is designed for easy installation. Follow the installation, removal and maintenance instructions given in this publication.

We recommend that the product be installed by a qualified technician. Only use the accessories recommended in this publication.

The product satisfies current EU regulations. The Manufacturer's specified limits of use must be observed scrupulously.

The Manufacturer is not liable if the limits of use are ignored and the recommended accessories are not employed, and if the installation instructions given in this publication are not followed to the full.

Les classifications se réfèrent aux prestations de chaque paumelle testée conformément à la norme EN1935:2002. Pour la capacité effective de la paumelle en fonction du nombre et du type de paumelle, du type de fixation, des caractéristiques du profil et des dimensions et du poids de la porte, faire référence à la section COEFFICIENT DE RÉDUCTION DU POIDS DU VANTAIL (CRP)

En cas d'application sur des portes particulièrement utilisées, il est fortement recommandé de lubrifier l'axe de la paumelle avec de la graisse (répéter l'opération au moins deux fois par an - voir figure 1).

L'efficacité et la sécurité de la pièce dépendent du respect de ces instructions, il est donc recommandé de les lire attentivement et de bien les comprendre avant d'utiliser la pièce.

L'article a été conçu pour être installé avec facilité. Il suffira de suivre attentivement les instructions de montage, démontage et entretien citées sur ces pages. Il est conseillé de confier l'installation de l'article à un technicien spécialisé.

Utiliser exclusivement les accessoires conseillés dans ce document.

L'article a été réalisé conformément aux normes européennes en vigueur.

Respecter impérativement les limites d'emploi prévues par le fabricant.

La responsabilité et la garantie du fabricant cessent si les limites d'emploi ne sont pas respectées, si les accessoires prévus ne sont pas utilisés et si les instructions de montage prévues dans ce document ne sont pas respectées.

Las clasificaciones se refieren a las prestaciones de cada bisagra, probadas según la norma EN1935:2002. Para la capacidad efectiva de la bisagra según el número y el tipo de bisagra, el tipo de fijación, las características del perfil y las dimensiones y el peso de la puerta, consultar la sección COEFICIENTE DE REDUCCIÓN PESO HOJA (CRP).

En caso de aplicación en puertas con alta frecuencia de apertura se recomienda lubricar el perno de la bisagra con grasa al menos dos veces al año (ver figura 1).

La eficacia y la seguridad del producto están garantizadas sólo si se cumplen estas instrucciones.

Por lo tanto, se recomienda leerlas con detenimiento y comprenderlas bien antes de utilizar el producto.

El producto ha sido diseñado para instalarse con facilidad.

Seguir detenidamente las instrucciones de montaje, desmontaje y mantenimiento.

Se recomienda hacer instalar el producto a personal especializado.

Utilizar exclusivamente los accesorios recomendados en este documento.

El producto está construido según las normas europeas vigentes.

Es fundamental respetar los límites de empleo previstos por el fabricante.

La responsabilidad y la garantía del fabricante quedan sin efecto si no se respetan los límites de empleo y/o el uso de los accesorios previstos o si no se cumplen las instrucciones de montaje contenidas en este documento.

Die Einstufungen beziehen sich auf die Leistungen des einzelnen Bands, das nach Norm EN1935:2002 geprüft ist. Für die effektive Tragfähigkeit des Bands in Abhängigkeit von der Anzahl der Bänder, des Bandtyps, der Befestigungsart, der Profilmernale, der Abmessungen und des Gewichtes der Tür siehe den Abschnitt REDUKTIONSFAKTOR DES FLÜGELGEWICHTES (CRP)

Werden die Bänder auf Türen mit hoher Öffnungsbeanspruchung eingesetzt, wird empfohlen, die Zapfen der Bänder mindestens zwei Mal pro Jahr einzufetten (siehe Abbildung 1).

Die Wirksamkeit und die Sicherheit des Produktes sind nur bei strikter Einhaltung der vorliegenden Anweisungen gewährleistet; es wird daher geraten, die Anweisungen vor dem Gebrauch des Produktes sorgfältig zu lesen und sich zu vergewissern, den Inhalt voll verstanden zu haben.

Das Produkt ist für einfache und schnelle Montage gebaut.

Lesen Sie sorgfältig die vorliegenden Montage-, Ausbau- und Wartungsanweisungen.

Es wird empfohlen, das Produkt von Fachkräften installieren zu lassen.

Ausschließlich das in dem vorliegenden Dokument empfohlene Zubehör verwenden.

Das Produkt ist in Entsprechung der gültigen europäischen Richtlinien hergestellt.

Es ist wichtig, dass die vom Hersteller vorgegebenen Anwendungsgrenzen strikt eingehalten werden.

Die Produkthaftung und die Garantie des Herstellers verfallen, wenn die Anwendungsgrenzen nicht eingehalten und/oder für das Zubehör die im vorliegenden Dokument aufgeführten Montageanweisungen missachtet werden.

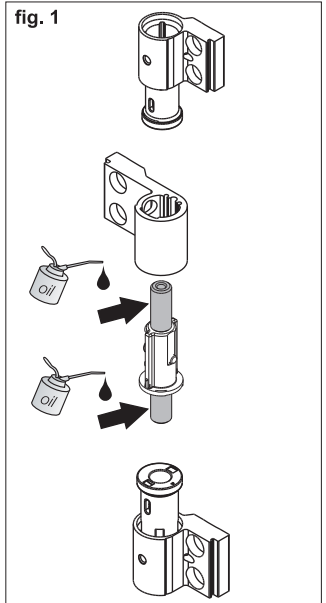
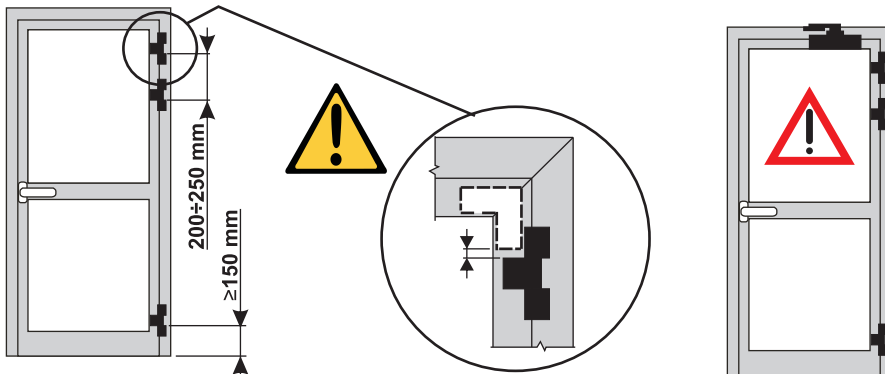

ATTREZZI NECESSARI PER IL MONTAGGIO
TOOLS REQUIRED FOR MOUNTING
FÜR DIE MONTAGE ERFORDERLICHE WERKZEUGE
HERRAMIENTAS NECESARIAS PARA EL MONTAJE
OUTILS NÉCESSAIRES POUR LE MONTAGE

LAVORAZIONI - WORKING - USINAGES
MECANIZADO - BEARBEITUNG

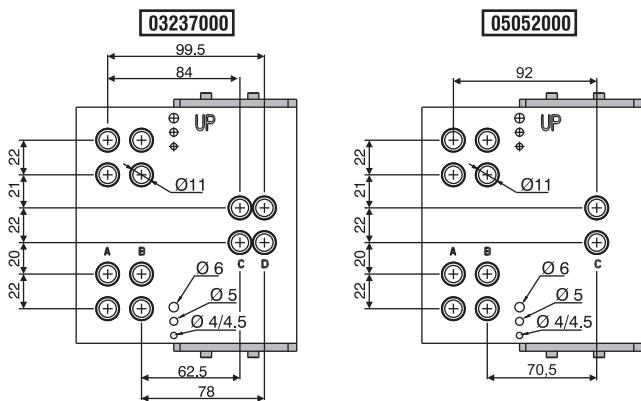
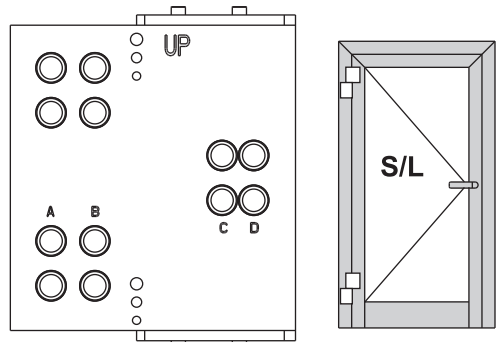
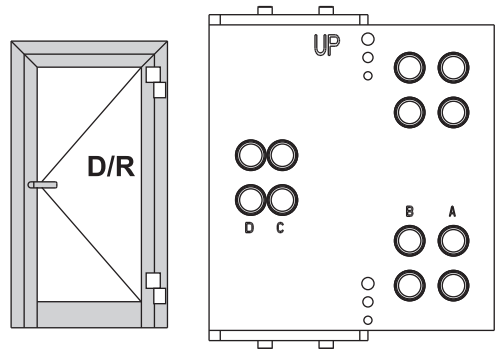
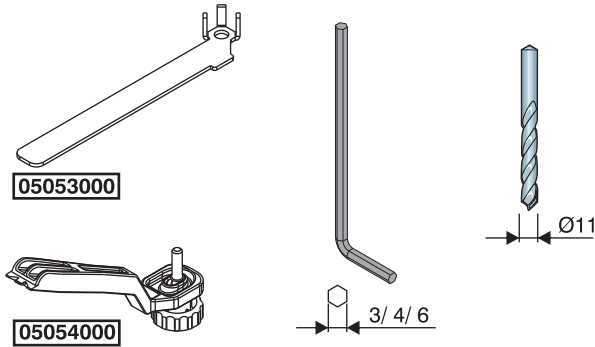

USO DELLA DIMA
TEMPLATE USING
UTILISATION DU GABARIT
USO DE LA PLANTILLA
ANWENDUNG DER BOHLEHRE

COMPLANARE - FLUSH
COPLANAIRE - COPLANAR - BÜNDIG

SORMONTO - OVERLAP
RECouvreMENT - RESALTE - ÜBERLAPPUNG

DIMA CON SPINE
TEMPLATE WITH PLUGS
GABARIT AVEC CHEVILLES
PLANTILLA CON TOPES
BOHREHRE MIT STECKER

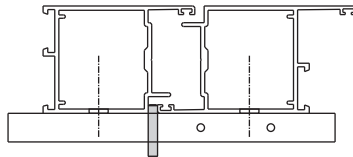

DIMA CON POSIZIONATORI
MACHINE - TEMPLATE WITH PLACERS
GABARIT AVEC POSITIONNEURS
PLANTILLA CON POSICIONADORES
BOHREHRE MIT POSIZIONIERERVORRICHTUNGEN

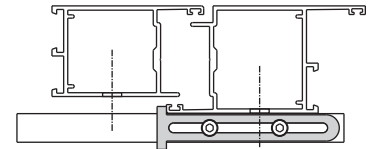
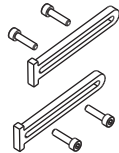

FORATURA
DRILLING
PERÇAGE
TALADRO
BOHRUNG

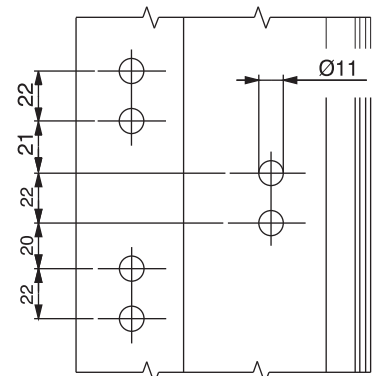
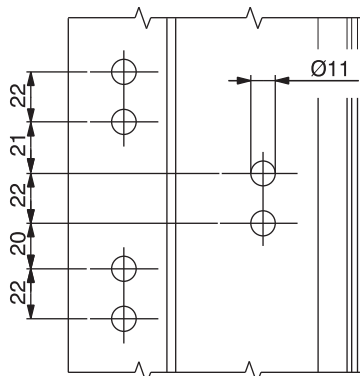

PORTATE MASSIME - MAXIMUM LOADS - CAPACIDADES MÁXIMAS - CHARGES MAXIMUM - MAXIMALEN TRAGFÄHIGKEITEN

Le portate sotto indicate sono valide anche per cerniere non complanari (gradino integrale e gradino abbinato)

The specified load capacities also apply to non-flush hinges (integral or combined step)

Les charges indiquées ci-dessus sont également valables pour les paumelles non coplanaires (cran intégral et cran assemblé)

Las capacidades antedichas son válidas también para las bisagras no coplanares (escalonado integral y combinado)

Die o. A. Tragfähigkeiten gelten auch für flächenversetzte bänder (stranggepresste stufe und kombistufe)

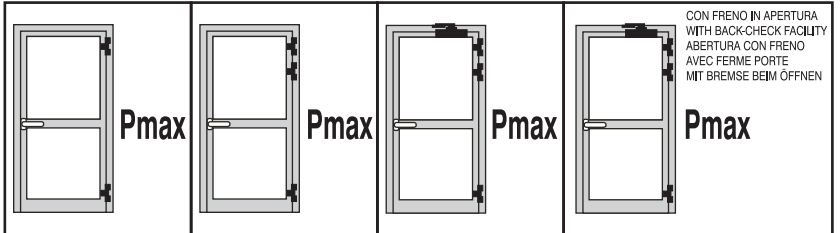

CON FRENO IN APERTURA
WITH BACK-CHECK FACILITY
ABERTURA CON FRENO
AVEC FERME PORTE
MIT BREMSE BEIM ÖFFNEN

| | | | | | |
|--|--|--------|--------|--------|--------|
| | | 180 kg | 200 kg | 170 kg | 115 kg |
| | | 140 kg | 160 kg | 135 kg | 90 kg |
| | | 140 kg | 160 kg | 135 kg | 90 kg |
| | | 140 kg | 160 kg | 135 kg | 90 kg |
| | | 120 kg | 140 kg | 120 kg | 80 kg |
| | | 120 kg | 140 kg | 120 kg | 80 kg |
| | | 180 kg | 200 kg | 170 kg | 115 kg |
| | | 140 kg | 160 kg | 135 kg | 90 kg |
| | | 140 kg | 160 kg | 135 kg | 90 kg |
| | | 140 kg | 160 kg | 135 kg | 90 kg |
| | | 120 kg | 140 kg | 120 kg | 80 kg |
| | | 120 kg | 140 kg | 120 kg | 80 kg |
| | | 140 kg | 160 kg | 135 kg | 90 kg |
| | | 120 kg | 140 kg | 120 kg | 80 kg |
| | | 120 kg | 140 kg | 120 kg | 80 kg |
| | | 120 kg | 140 kg | 120 kg | 80 kg |
| | | 100 kg | 120 kg | 100 kg | 70 kg |
| | | 100 kg | 120 kg | 100 kg | 70 kg |

COEFFICIENTE DI RIDUZIONE PESO ANTA (CRP) IN FUNZIONE DELLE DIMENSIONI
DOOR WEIGHT REDUCTION COEFFICIENT (CRP) AS A FUNCTION OF SIZE
COEFFICIENT DE RÉDUCTION DU POIDS DU VANTAIL (CRP) EN FONCTION DES DIMENSIONS
COEFICIENTE DE REDUCCIÓN PESO HOJA (CRP) SEGÚN LAS DIMENSIONES
REDUKTIONSFAKTOR DES FLÜGELGEWICHES (CRP) IN ABHÄNGIGKEIT VON DEN ABMESSUNGEN

| | | | | | | | | | | | | | | | | | | | | |
|------|--|------|-----|-----|------|------|------|------|------|------|------|------|------|------|------|------|------|------|------|------|
| H | Altezza anta (mm) - Altura hoja (mm) - Wing height (mm) - Flügelhöhe (mm) - Hauteur vantail (mm) | 4000 | 1 | 1 | 1 | 1 | 1 | 1 | 1 | 1 | 1 | 1 | 1 | 1 | 1 | 1 | 1 | 1 | 1 | 1 |
| | | 3900 | 1 | 1 | 1 | 1 | 1 | 1 | 1 | 1 | 1 | 1 | 1 | 1 | 1 | 1 | 1 | 1 | 1 | 0,95 |
| | | 3800 | 1 | 1 | 1 | 1 | 1 | 1 | 1 | 1 | 1 | 1 | 1 | 1 | 1 | 1 | 1 | 1 | 1 | 0,90 |
| | | 3700 | 1 | 1 | 1 | 1 | 1 | 1 | 1 | 1 | 1 | 1 | 1 | 1 | 1 | 1 | 1 | 1 | 0,95 | 0,87 |
| | | 3600 | 1 | 1 | 1 | 1 | 1 | 1 | 1 | 1 | 1 | 1 | 1 | 1 | 1 | 1 | 1 | 1 | 0,90 | 0,83 |
| | | 3500 | 1 | 1 | 1 | 1 | 1 | 1 | 1 | 1 | 1 | 1 | 1 | 1 | 1 | 1 | 0,94 | 0,86 | 0,80 | |
| | | 3400 | 1 | 1 | 1 | 1 | 1 | 1 | 1 | 1 | 1 | 1 | 1 | 1 | 1 | 0,90 | 0,83 | 0,77 | | |
| | | 3300 | 1 | 1 | 1 | 1 | 1 | 1 | 1 | 1 | 1 | 1 | 1 | 0,94 | 0,85 | 0,79 | 0,75 | | | |
| | | 3200 | 1 | 1 | 1 | 1 | 1 | 1 | 1 | 1 | 1 | 1 | 1 | 0,89 | 0,82 | 0,76 | 0,71 | | | |
| | | 3100 | 1 | 1 | 1 | 1 | 1 | 1 | 1 | 1 | 1 | 1 | 0,94 | 0,85 | 0,78 | 0,73 | 0,69 | | | |
| | | 3000 | 1 | 1 | 1 | 1 | 1 | 1 | 1 | 1 | 1 | 1 | 0,88 | 0,81 | 0,75 | 0,70 | 0,67 | | | |
| | | 2900 | 1 | 1 | 1 | 1 | 1 | 1 | 1 | 1 | 1 | 0,93 | 0,84 | 0,76 | 0,72 | 0,68 | 0,65 | | | |
| | | 2800 | 1 | 1 | 1 | 1 | 1 | 1 | 1 | 1 | 0,88 | 0,80 | 0,74 | 0,69 | 0,65 | 0,63 | | | | |
| | | 2700 | 1 | 1 | 1 | 1 | 1 | 1 | 1 | 0,93 | 0,83 | 0,76 | 0,71 | 0,67 | 0,63 | 0,61 | | | | |
| | | 2600 | 1 | 1 | 1 | 1 | 1 | 1 | 1 | 0,88 | 0,79 | 0,72 | 0,68 | 0,64 | 0,61 | 0,59 | | | | |
| | | 2500 | 1 | 1 | 1 | 1 | 1 | 1 | 0,93 | 0,83 | 0,75 | 0,69 | 0,65 | 0,62 | 0,60 | X | | | | |
| 2400 | 1 | 1 | 1 | 1 | 1 | 0,87 | 0,78 | 0,71 | 0,67 | 0,63 | 0,60 | X | X | | | | | | | |
| 2300 | 1 | 1 | 1 | 1 | 0,93 | 0,81 | 0,74 | 0,68 | 0,64 | 0,61 | X | X | X | | | | | | | |
| 2200 | 1 | 1 | 1 | 1 | 0,85 | 0,76 | 0,70 | 0,65 | 0,61 | X | X | X | X | | | | | | | |
| 2100 | 1 | 1 | 1 | 1 | 0,91 | 0,80 | 0,72 | 0,67 | 0,63 | 0,59 | X | X | X | X | | | | | | |
| 2000 | 1 | 1 | 1 | 1 | 0,85 | 0,75 | 0,68 | 0,64 | 0,60 | X | X | X | X | X | | | | | | |
| | | 600 | 700 | 800 | 900 | 1000 | 1100 | 1200 | 1300 | 1400 | 1500 | 1600 | 1700 | 1800 | 1900 | 2000 | | | | |

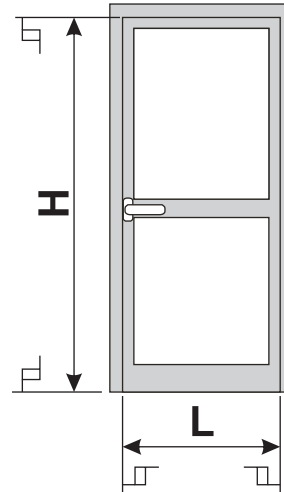

X Dimensioni non realizzabili
 Not possible dimensions
 Dimensiones no admitidas
 Dimensions Irréalisable
 Nicht zulässige abmessungen

L Larghezza anta (mm) - Anchura hoja (mm) - Wing width (mm)
 Flügelbreite (mm) - Largeur vantail (mm)

Pour obtenir le poids maximum effectif (P) de l'ouvrant, il faut multiplier la valeur Pmax choisie dans le **Tableau des charges maximum** (page 4) par le coefficient de réduction du poids (CRP) correspondant aux dimensions du châssis.

Exemple:

L x H = 1200 x 2800 mm

n°2 paumelles 62,5 avec contre plaques

épaisseur profil 1,8 mm

Pmax = 180 kg

CRP = 1

P = 180 x 1 = 180 kg

Per ottenere il peso massimo effettivo (P) dell'anta, moltiplicare il valore Pmax scelto nella **Tabella delle portate massime** (pag. 4) per il coefficiente di riduzione peso (CRP) corrispondente alle dimensioni dell'infisso (LxH).

Esempio:

L x H = 1200 x 2800 mm

n°2 cerniere 62,5 con contropiastre

spessore profilo 1,8 mm

Pmax = 180 kg

CRP = 1

P = 180 x 1 = 180 kg

Para obtener el peso máximo efectivo (P) de la hoja, multiplicar el valor Pmax elegido en la **Tabla de capacidades máximas** (pág. 4) por el coeficiente de reducción peso (CRP) correspondiente a las dimensiones del cerramiento (LxH).

Ejemplo:

L x H = 1200 x 2800 mm

2 bisagras 62,5 con contraplaca

espesor perfil 1,8 mm

Pmax = 180 kg

CRP = 1

P = 180 x 1 = 180 kg

To obtain the real sash maximum weight (P) multiply the Pmax value chosen in the **Maximum load chart** (page 4) for the weight reduction coefficient (CRP) corresponding to the sash size (W x H)

Example:

W x H = 1200 x 2800 mm

No. 2 hinges C/C 62,5 with counterplates

Profile thickness 1,8 mm

Pmax = 180 kg

CRP = 1

P = 180 x 1 = 180 kg

Um das effektive Höchstgewicht (P) des Flügels zu erhalten, den der **Tabelle der maximalen Tragfähigkeiten entnommenen Wert Pmax** (Seite 4) mit dem Reduktionsfaktor des Flügelgewichtes (CRP) der betreffenden Türabmessungen (BxH) multiplizieren.

Beispiel:

B x H = 1200 x 2800 mm

2 Bänder 62,5 mit Schließplatten

Profildicke 1,8 mm

Pmax = 180 Kg

CRP = 1

P = 180 x 1 = 180 kg

ASSEMBLAGGIO CERNIERA - HINGE ASSEMBLY - ENSAMBLAJE BISAGRA - ASSEMBLAGE PAUMELLE - BANDMONTAGE

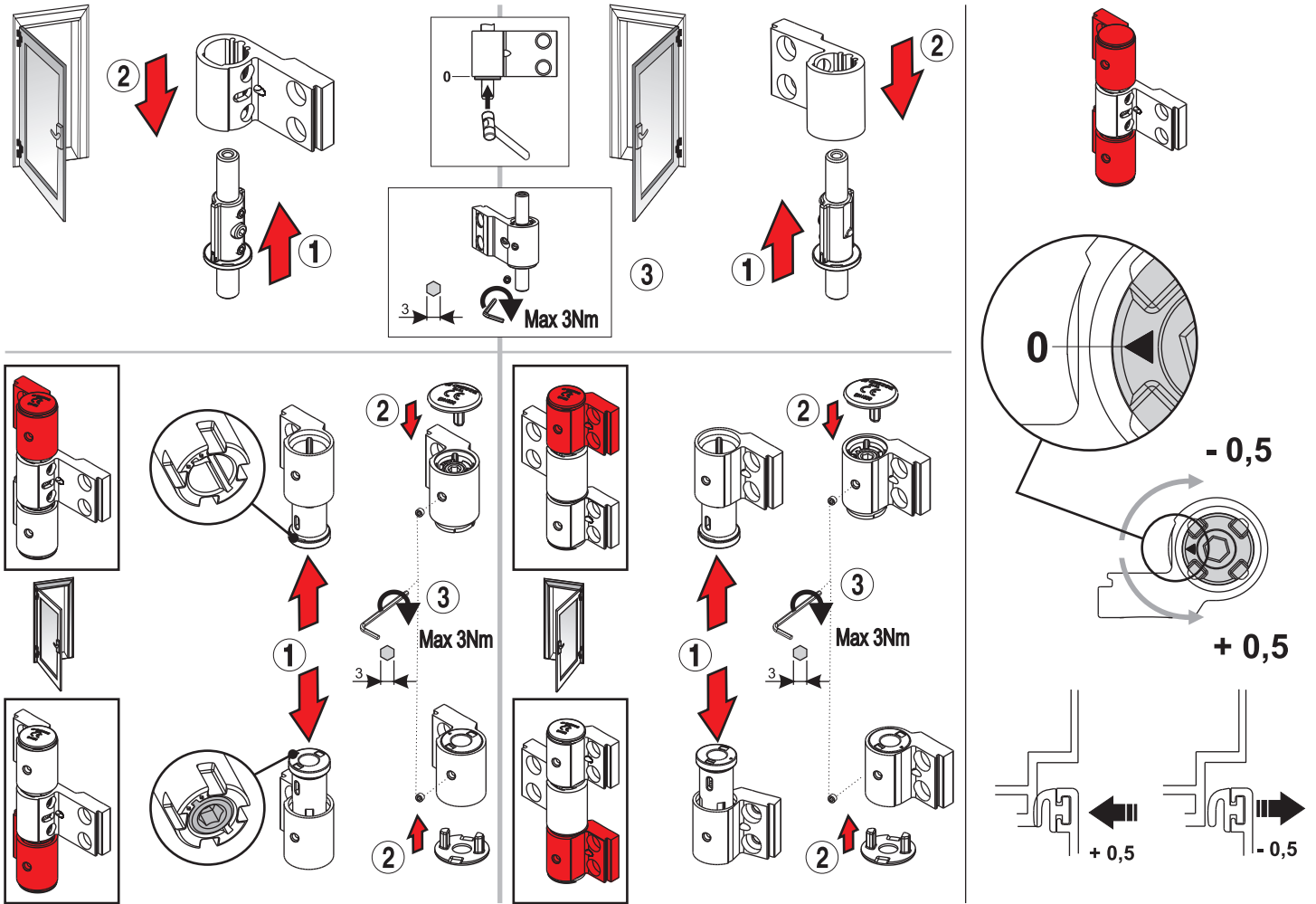

SISTEMI DI FISSAGGIO-FIXING SYSTEMS-SYSTEMES DE FIXATION-SISTEMA DE FIJACION-BEFESTIGUNGSSYSTEME

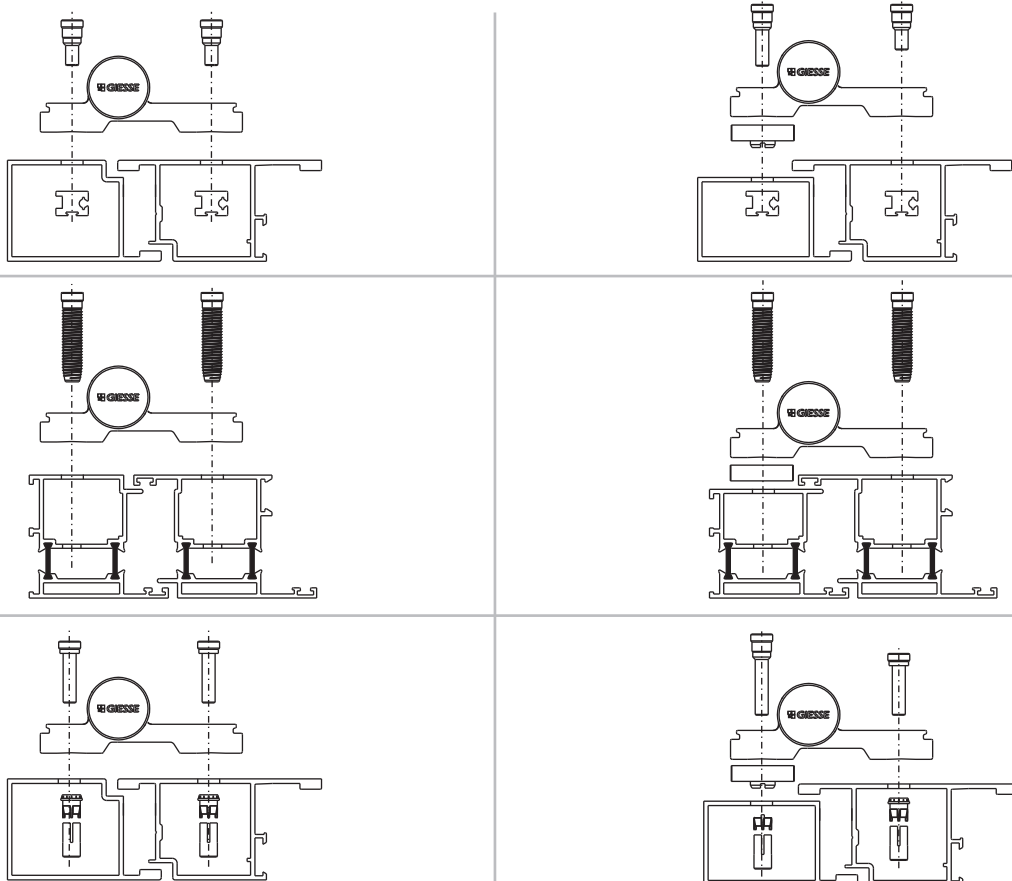

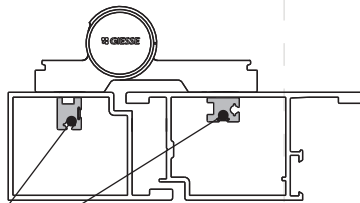
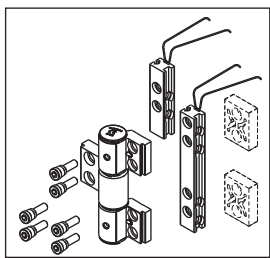
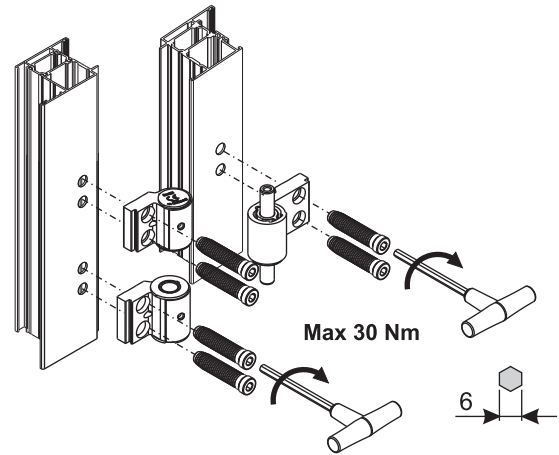
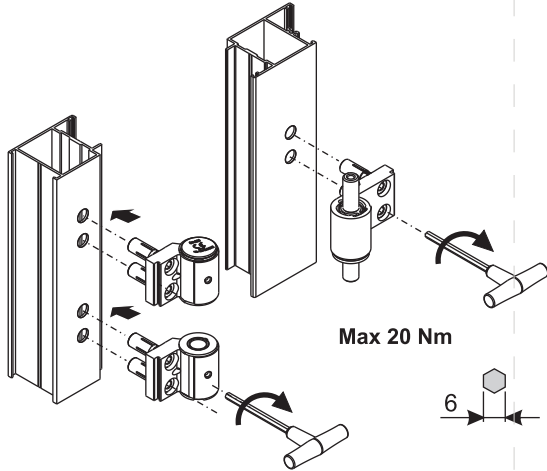
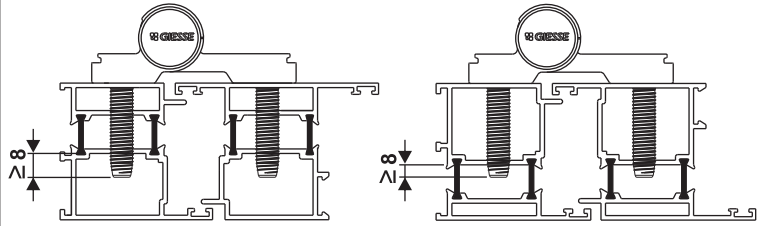
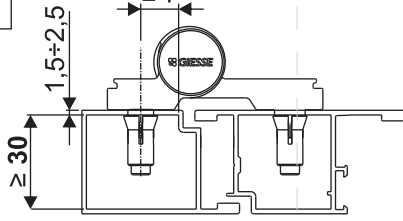
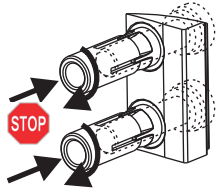
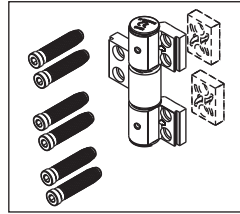
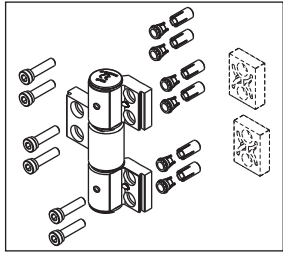

SOLO APERTURA ESTERNA
OUTWARD OPENING ONLY
UNIQUEMENT OUVERTURE VERS L'EXTÉRIEUR
PARA APERTURA EXTERNA
NUR FÜR AUSSEN ERÖFFNUNG

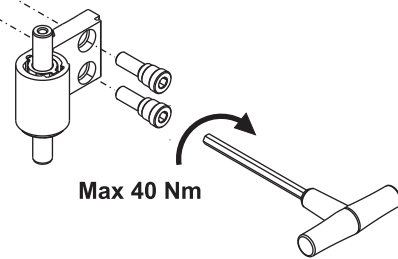
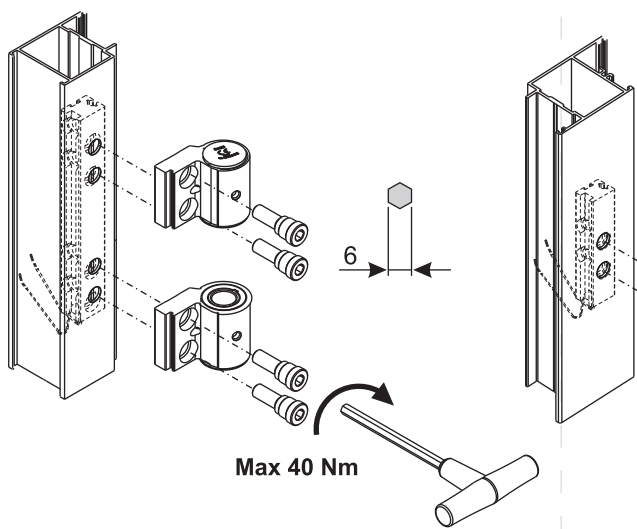
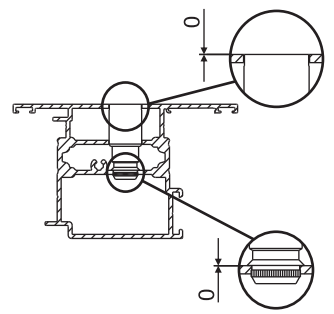
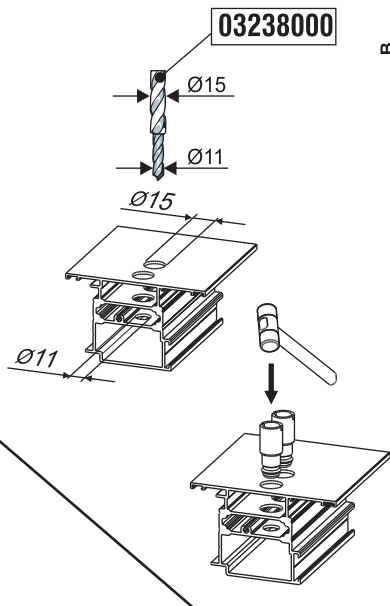
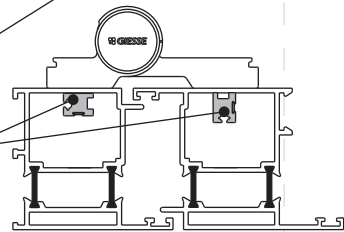
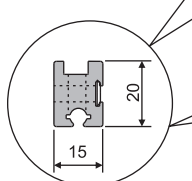
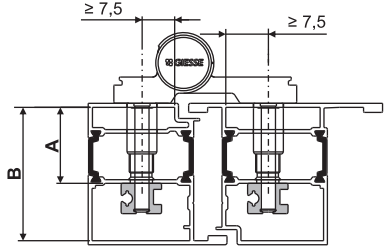

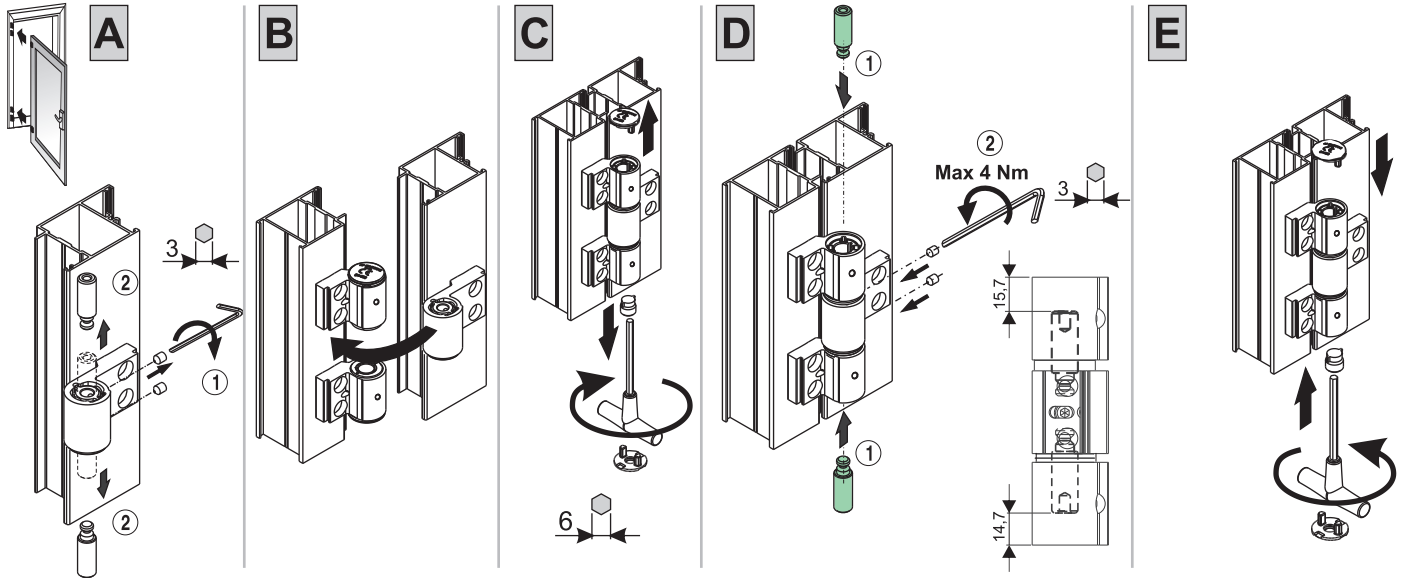

REGOLAZIONI - ADJUSTMENTS - RÉGLAGES - REGULACIONES - JUSTAGE

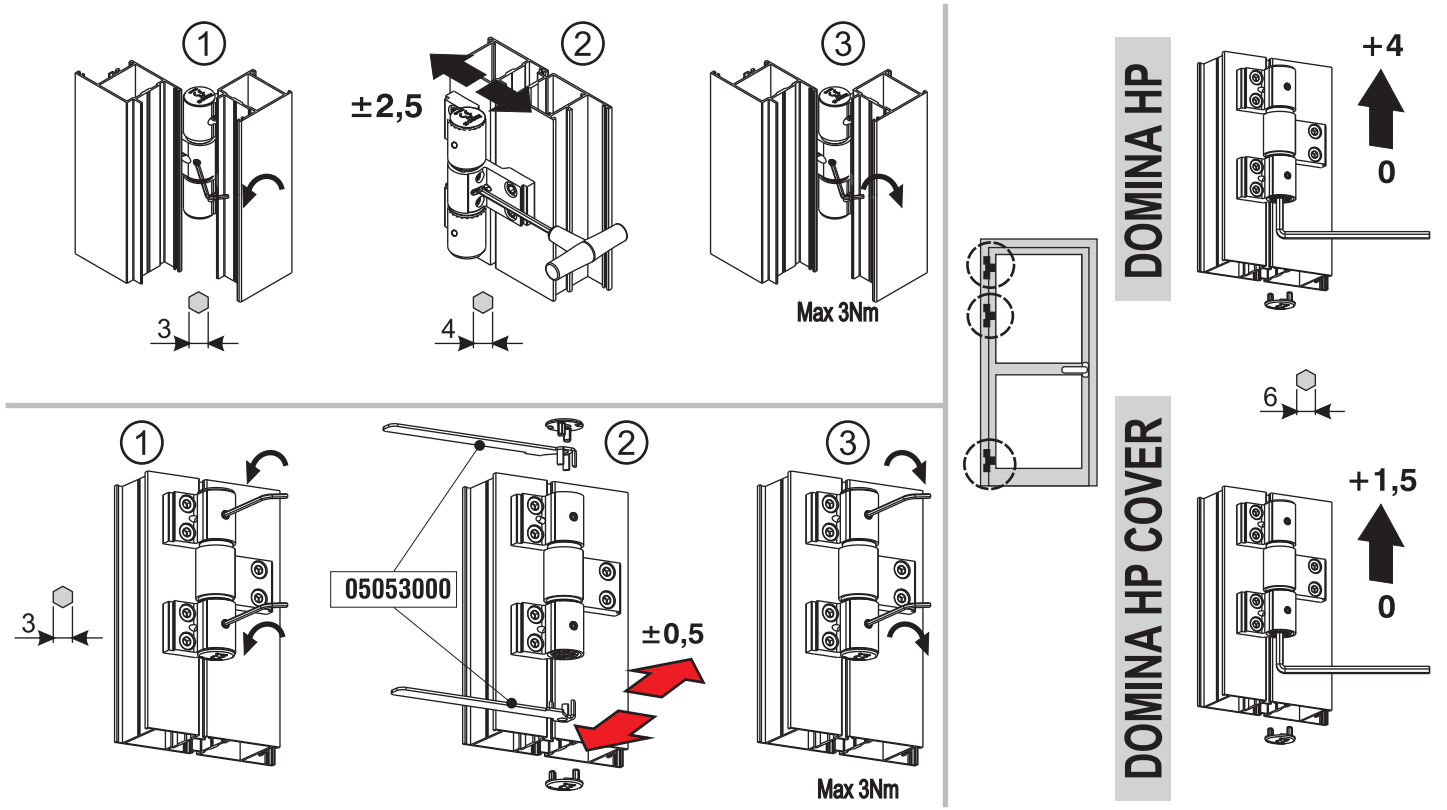

OPERAZIONI FINALI - FINAL OPERATIONS - OPÉRATIONS FINALES - OPERACIONES FINALES - ENDBEARBEITUNG

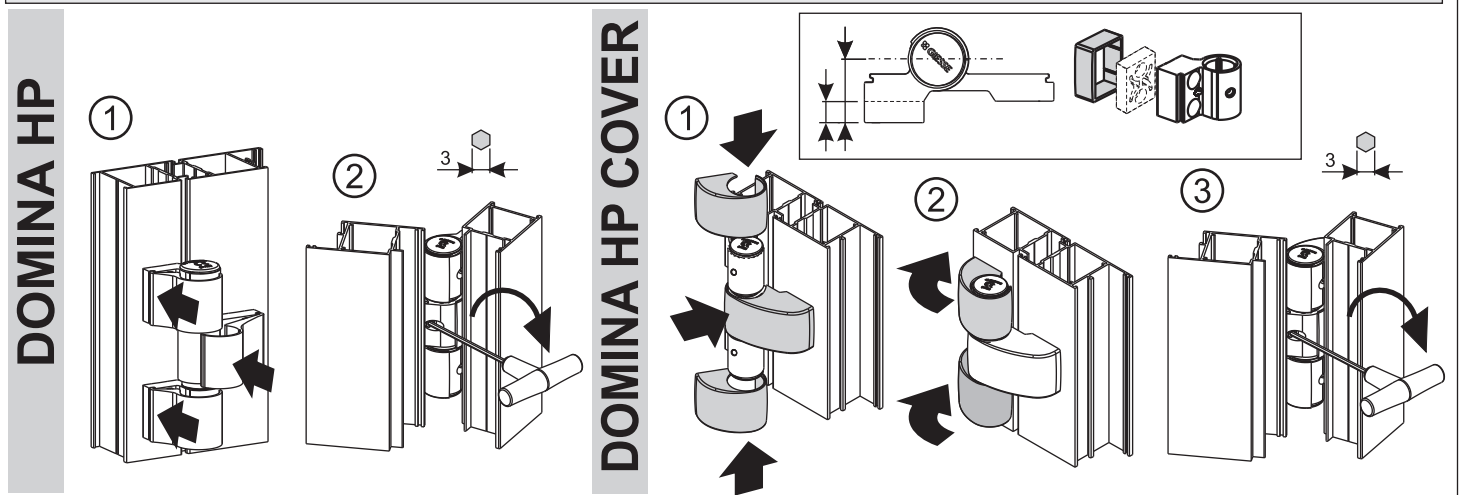



A

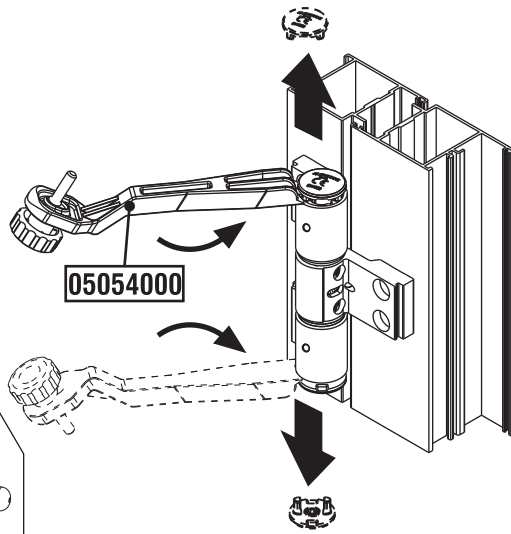

B

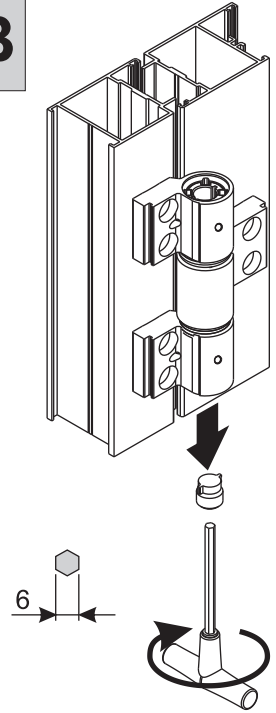

DOMINA HP

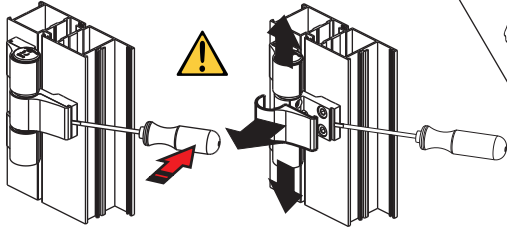

C

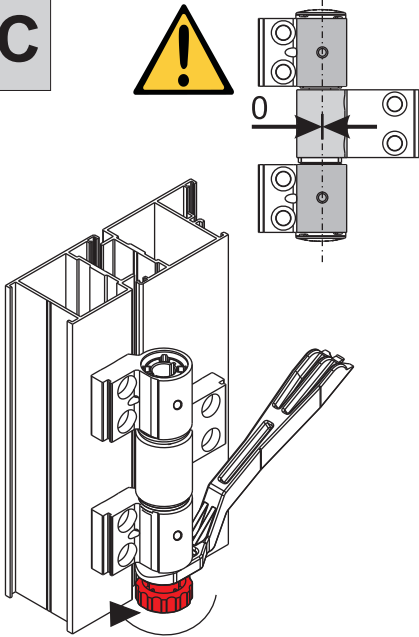

D

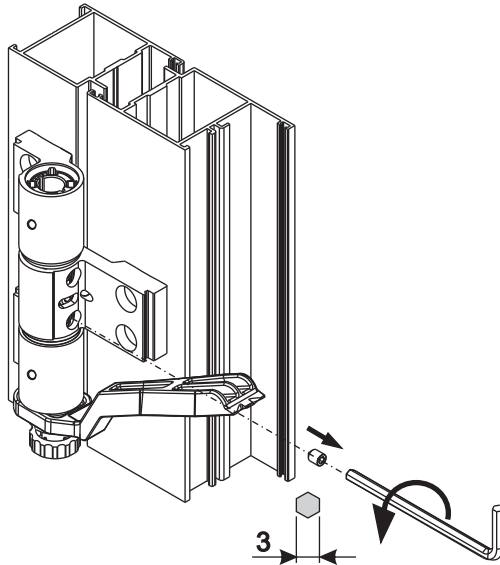

F

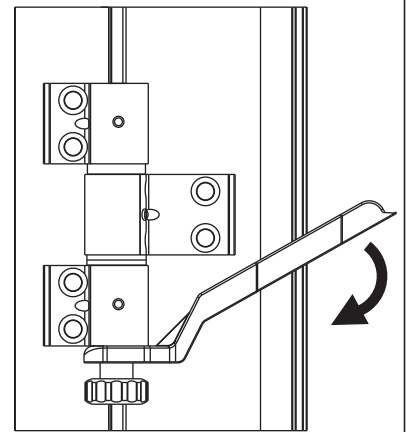

G

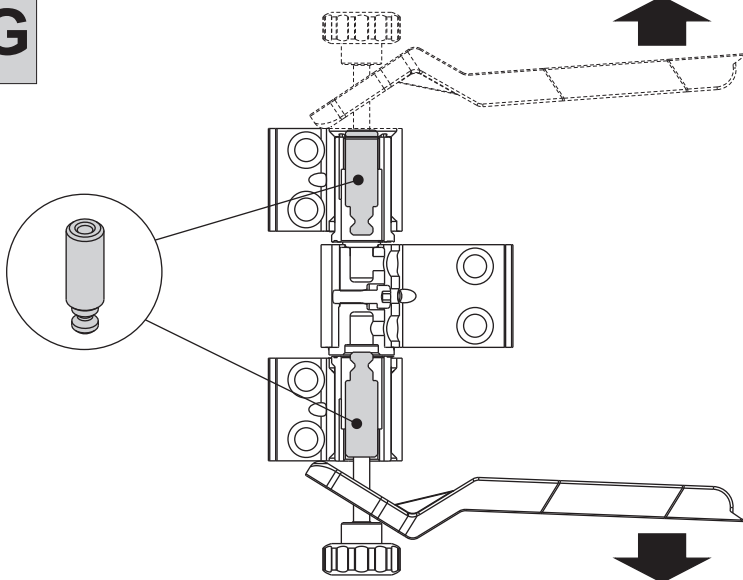

H

